

StoneLedge

>>> 12" STANDARD

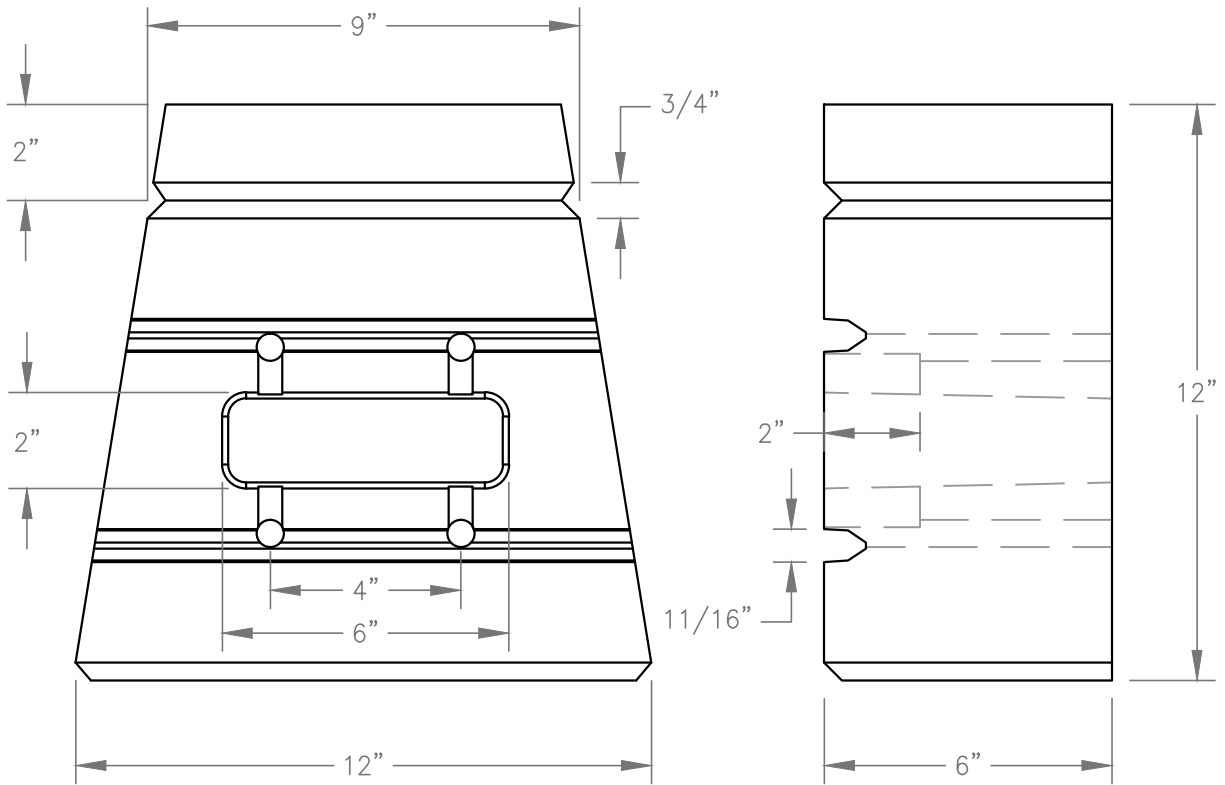

CORNERSTONE
WALL SOLUTIONS INC.

These preliminary details are intended solely to act as an aid when designing a wall. This drawing should not be used for final design or construction. Each site-specific wall should be certified and signed by a registered geotechnical engineer in the State or Province that it is being built. The accuracy and use of the details in this document are the sole responsibility of the user.

www.cornerstonewallsolutions.com